



UNIVERSITY OF CAPE TOWN
IYUNIVESITHI YASEKAPA • UNIVERSITEIT VAN KAAPSTAD
ENGINEERING & THE BUILT ENVIRONMENT



UNIVERSITY OF THE
WITWATERSRAND,
JOHANNESBURG



Durability Index Testing Procedure Manual

2018

(Ver 4.5.1, April 2018)

CONTENTS

PREFACE	1
PART 1: STANDARD PROCEDURE FOR PREPARATION OF TEST SPECIMENS	2
1.1 SCOPE	2
1.2 TEST SPECIMENS	2
1.3 APPARATUS	2
1.4 PREPARATION OF SPECIMENS FROM CUBES	3
1.5 PREPARATION OF SPECIMENS FROM SITE ELEMENTS	4
1.6 REFERENCES	4
1.7 REVISIONS	5
PART 2: STANDARD PROCEDURE FOR OXYGEN PERMEABILITY TEST	6
2.1 SCOPE	6
2.2 APPARATUS	6
2.3 TEST SPECIMENS	8
2.4 CONDITIONING OF SPECIMENS	8
2.5 TESTING OF SPECIMENS	8
2.6 CALCULATIONS	10
2.7 REPORTING	13
2.8 REFERENCES	13
2.9 REVISIONS	14
APPENDIX A (Part 2)	16
APPENDIX B (Part 2)	17
PART 3: STANDARD PROCEDURE FOR WATER SORPTIVITY AND POROSITY TEST	22
3.1 SCOPE	22
3.2 APPARATUS	22
3.3 TEST SPECIMENS	23
3.4 CONDITIONING OF SPECIMENS	23
3.5 TESTING OF SPECIMENS	24
3.6 CALCULATIONS	26
3.7 REPORTING	29
3.8 REFERENCES	30
3.9 REVISIONS	30
PART 4: STANDARD PROCEDURE FOR CHLORIDE CONDUCTIVITY TEST	32
4.1 SCOPE	32
4.2 APPARATUS	32
4.3 PREPARATION OF THE CHEMICAL SOLUTION (5M NaCl)	34
4.4 TEST SPECIMENS	34
4.5 CONDITIONING OF SPECIMENS	34
4.6 TESTING OF SPECIMENS	35
4.7 CALCULATIONS	37
4.8 REPORTING	38
4.9 REFERENCES	38
4.10 REVISIONS	39
APPENDIX A (Part 4)	41

PREFACE

This version of the Durability Index Testing Procedure Manual contains a number of new aspects. The most important is that Parts 1, 2, and 4 have been formalised as SANS Test Methods: SANS 3001-CO3-1:2015, SANS 3001-CO3-2:2015, and SANS 3001-CO3-3:2015, respectively. Part 3, the Water Sorptivity and Porosity Test Procedure, must still be formalised through the SABS processes. It is important to note that if there are discrepancies between this Manual and the SANS Tests, the SANS Tests will govern. However, the SANS tests will themselves undergo a review for improvements and clarifications in the future (2018).

There are no substantive changes in the test methods compared with earlier versions, but the wording has been improved to make them clearer, tighter restrictions have been placed on the CCI test (time for taking the measurements), the figures have been improved, and other detail added. Illustrative calculations have also been added as an Appendix in the OPI Test Method, and precision data have been added where appropriate.

The other change to note is the inclusion of porosity as an important parameter in the water sorptivity test. While determining porosity has always been a part of the test, this parameter is now being realised as important in its own right, and water sorptivity cannot be viewed in isolation of porosity. Ideally, a potentially durable concrete should have both low water sorptivity and low porosity values.

Please report any comments or errors to the Civil Engineering Department at UCT.

MG Alexander, February 2017 (rev July 2017; January, April 2018)

CONCRETE DURABILITY INDEX TESTING MANUAL

PART 1: STANDARD PROCEDURE FOR PREPARATION OF TEST SPECIMENS

1.1 SCOPE

This method describes how to cut and prepare test specimens to perform the concrete durability index tests, as originally described by Alexander, Ballim and Mackechnie ⁽¹⁾.

Where durability index results are required for concrete mix acceptance and mix design purposes, representative samples can be prepared from concrete cubes, cast and cured in the laboratory. Where durability index results are required for quality control purposes on site, representative samples shall be taken from the structure itself, or from trial panels representative of the structure in terms of concrete mix proportions, finishing and curing, and environmental exposure.

This method shall not be used for concrete with a maximum nominal aggregate size exceeding 26.5 mm.

1.2 TEST SPECIMENS

The test specimens considered in this method statement are circular discs prepared by coring and cutting concrete cubes in the laboratory, or by taking cores from concrete elements on site. Concrete cubes shall be cast and cured in accordance with project specifications, but their dimensions shall not be less than 100 mm.

The duration and method of curing, and the concrete age at the time of testing, shall be recorded.

The specimens shall be 70 ± 2 mm in diameter, and shall be 30 ± 2 mm thick concrete discs.

Note: Core barrels are available in slightly different internal diameter sizes (typically between 68 mm and 70 mm). The specimen should fit snugly into the rubber collar used for the specific test, so that no leaks occur.

For specimens from cubes, the direction of coring shall be perpendicular to the casting direction.

Specimens materially damaged during the coring and cutting process, for example aggregate particles excessively chipped from the surface to be tested, shall not be used. Any damage shall be such that neither the seal against the rubber collar nor the thickness of the specimen are materially compromised.

After coring, the specimen shall be kept at ambient conditions in the laboratory for a maximum of 3 days before cutting. The durability index conditioning shall be started immediately after cutting.

1.3 APPARATUS

- a) A water-cooled diamond-tipped core barrel, with a nominal internal diameter of 70 mm, attached to a suitable coring drill.

- b) A holding device in which cubes can be clamped firmly and securely to ensure they remain in position while coring takes place.
- c) A water-cooled moveable bed diamond saw.

1.4 PREPARATION OF SPECIMENS FROM CUBES

- a) Coring of cubes shall take place at 28 ± 3 days after casting, unless otherwise required by the project specifications.
- b) Clamp the cube firmly into the holding device and place the core barrel perpendicular to and in the centre of the concrete face to be cored (with a tolerance of 2 mm in any direction).
- c) Core entirely through the cube, ensuring that when the far side is reached and the core breaks off, the extent of the rough zone created is not greater than 5 mm from the end of the core. This may require slowing the speed of travel of the core drill as it approaches the far side. The sides of the core shall be parallel and within 5° of perpendicular to the face.
- d) Remove the surface 5 mm from the exterior face(s) of the core by cutting.
- e) Cut the required thickness of 30 ± 2 mm of the test specimen(s) from the core.

Note: Steps d) and e) above are illustrated in Figure 1.1, for the case of extracting 2 surface discs, one from each cast face of the cube.

- f) Allocate and mark the specimen(s) with a reference number on the interior face with a permanent marker.

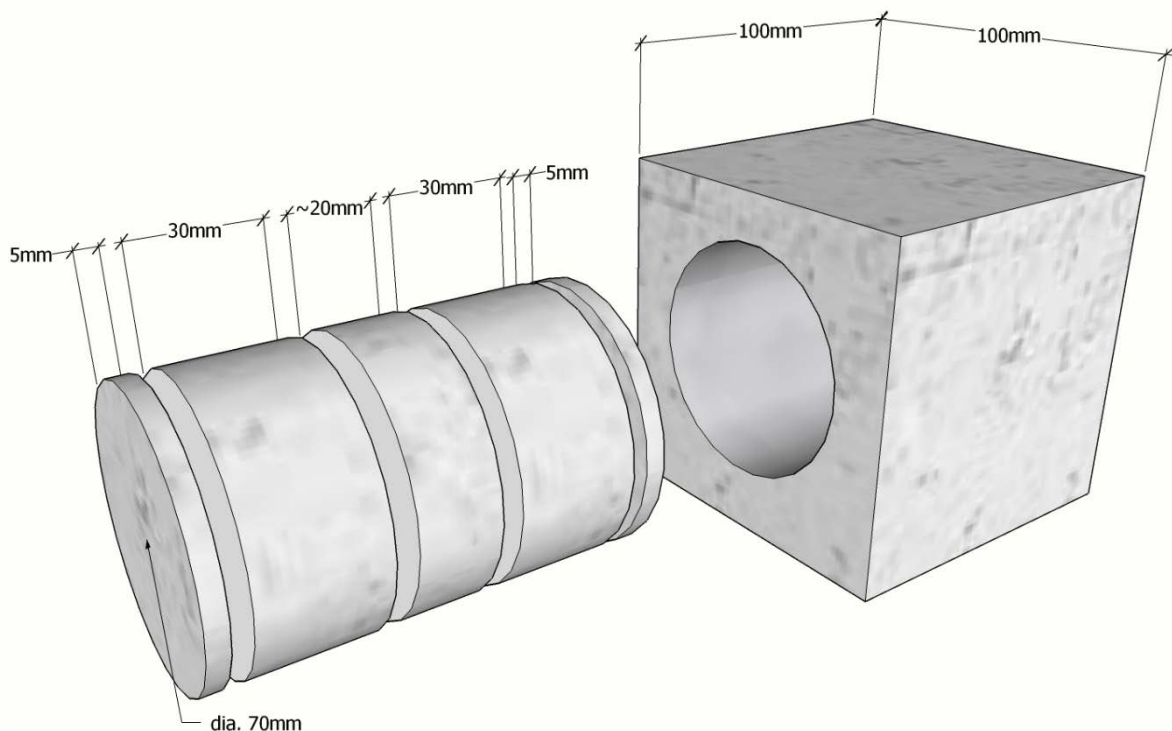

Figure 1.1. Details of cutting discs from 100 mm cube

1.5 PREPARATION OF SPECIMENS FROM SITE ELEMENTS

Note: This section only describes the procedure of preparation of test specimens from site concrete elements. The project specifications should indicate frequency and number of cores per exposed surface area of concrete elements.

- a) Coring of the specimen from site concrete elements shall take place between 28 d and 35 d after casting, unless otherwise required by the project specifications.
- b) Place and firmly secure the core barrel perpendicular to the surface of the concrete.
- c) Core to a depth of between 80 mm and 100 mm. Ensure that the sides of the core are parallel and within 5° perpendicular to the face.
- d) Break off the core from the concrete face with a hammer and chisel, ensuring that the 35 mm nearest the surface is undamaged.
- e) Mark each core with a reference number, place in a sealed bag, and send to the laboratory for further preparation.
- f) After coring, the specimen(s) shall be kept at ambient conditions in the laboratory for a maximum of 3 days before cutting. The durability index conditioning shall be started immediately after cutting.
- g) Cut the surface 5 mm from the exposed face of the core and discard. Cut the required thickness (30 ± 2 mm) of the test specimen from the core.
- h) Where a specimen is damaged during this process, for example where aggregate excessively chips from the surfaces to be tested, the specimen shall not be used for testing.
- i) Cores from site elements must be protected from conditions of adverse drying and damage on site, and during transport to a laboratory. These conditions may include, inter alia, high drying temperature and/or very low humidity, rough handling and impact, etc. It is good practice to wrap samples in plastic-wrap or a sealed plastic bag and transport them in a container that protects them from shock, damage, and high temperatures.

1.6 REFERENCES

- (1) Alexander MG, Ballim Y, Mackechnie JM, 'Concrete durability index testing manual' Research Monograph No. 4, Departments of Civil Engineering, University of Cape Town and University of the Witwatersrand, March 1999.
- (2) Gouws S, 'Durability Index Approach – Method Statements.' Document submitted to the Durability Index Test Method working group (under the auspices of the C&CI Technical Committee), University of the Witwatersrand, 14 August 2003.
- (3) Gouws SM, 'Durability Index Approach – Progress Report 1: Method Statements Summary document of major amendments to Durability Index Test Methods as agreed upon by Durability Index Test Method working group (Under the auspices of the C&CI Technical Committee, University of the Witwatersrand, 19 August 2003.)
- (4) Gouws SM, 'Durability Index Approach – Progress Report 2: Method Statements. Summary document of major amendments to Durability Index Test Methods as agreed upon by Durability

Index Test Method Working Group (Under the auspices of the C&CI Technical Committee, University of the Witwatersrand, 7 October 2003.)

1.7 REVISIONS

Note: Revisions below may refer to older versions with different clause numbers to this version.

Revisions	Description	Date
A	For approval	8 April 2002
B	Indicated with subscript B	15 May 2002
C	K. Stanish (KS) – remove marked with strike through, added in bold, comments in italics	13 Feb 2003
C1	S. Gouws – suggested changes in red, comments/questions in red italics, see also reference 2	16 July 2003
D	For approval after Durability Index Test Method meeting on 19 August 2003, see also reference 3	19 August 2003
E	For approval after Durability Index Test Method meeting on 22 September 2003, see also reference 4	22 September 2003
F	Editorial improvements and clarifications – M. G. Alexander (MGA)	April-July 2004
G	KS – Clarification and illustration	May 2005
H	MGA – Editorial corrections	Jan/Oct 2007
I	MGA – Editorial and other corrections	Sep-Oct 2008
J	MGA Cl. 5 c) Core to depth of 80-100 mm Cl. 5 i) new clause added, to cover transport of cores from site Cl. 5 j) original Cl 5 i)	February 2009
K	SG as agreed with MGA 2.d, 3 and 5 – The option of using the facing machine was omitted	May 2010
L	MGA & Chad Ludwig (CL) – Editorial changes; also to correspond to SANS 3001-CO3-1:2015	Oct-Nov 2016

CONCRETE DURABILITY INDEX TESTING MANUAL

PART 2: STANDARD PROCEDURE FOR OXYGEN PERMEABILITY TEST

2.1 SCOPE

This test method sets out the procedure for determining the oxygen permeability index as originally described by Alexander, Ballim and Mackechnie⁽¹⁾. The method described herein supersedes the 1999 version in ref. 1.

The test is suitable for the evaluation of materials and mix proportions for design purposes, and for research and development. The test can also be used for quality control of concrete on site. It is not recommended that this test be performed before 28 days after casting. Specimen age may have a significant effect on the test results, depending on the type of concrete and the curing procedure.

The oven drying procedure has been selected to result in a minimal degree of microstructural alteration of the concrete specimens, while still giving minimal uniform moisture content. Research has shown, however, that significant amounts of microstructural damage may occur for some high quality concrete⁽²⁾, notably high strength concrete incorporating silica fume. Thus care should be taken in interpreting the test results from these concretes.

This test method shall not be used for concrete with a maximum nominal aggregate size exceeding 26.5 mm.

2.2 APPARATUS

- a) An oven capable of maintaining a temperature of $50 \pm 2^\circ\text{C}$.

Note: Most laboratory ovens are of the forced draft, ventilated type. If, however, the oven being used is of the closed (unventilated) type, then the relative humidity inside the oven must be maintained by the inclusion of trays of saturated calcium chloride solution. The trays should provide a total exposed area of at least 1 m^2 per 1 m^3 of volume of the oven and should contain sufficient solid calcium chloride to show above the surface of the solution throughout the test.

- b) Permeability cell as shown in Figure 2.1. The permeability cell should have a volume of 5 L with a tolerance of $\pm 5\%$, and of construction such that it does not expand or contract in the pressure range 0 kPa to 120 kPa. The cell should be housed in a room where the temperature is controlled at $23 \pm 2^\circ\text{C}$. The airtightness of the equipment needs to be tested regularly using impermeable blank specimens, manufactured from, for example, rigid PVC. A drop of 0 kPa in pressure from an initial permeability cell pressure of 100 kPa over a 24 hour period is required.
- c) Compressible rubber collars with Shore hardness 39A, as shown in Figure 2.2, for each cell, that allow a tight fit around the specimen to eliminate any leakage of oxygen, except through the pores of the specimen. The collars shall be free of cracks and tears.

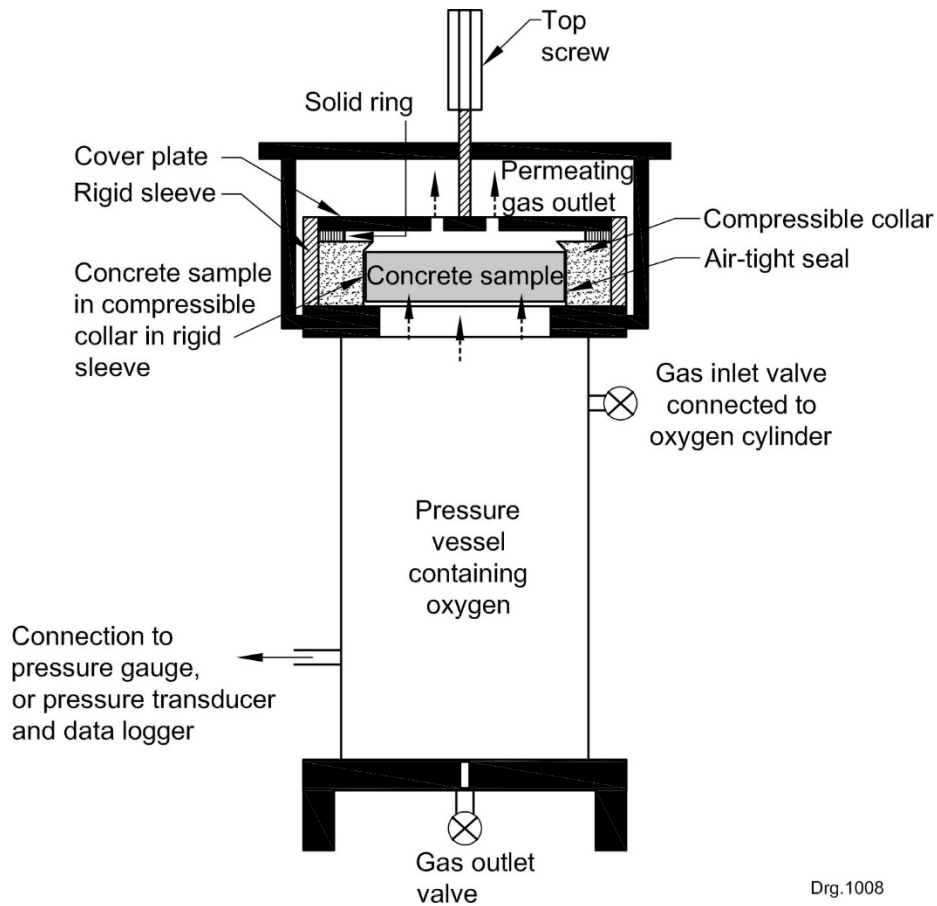

Drg.1008

Figure 2.1. Permeability Cell Arrangement

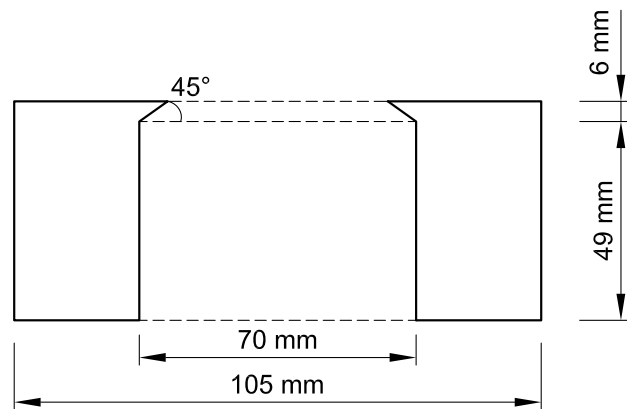

Drg.1008a

Figure 2.2. Compressible Collar Cross-section.

d) Pressure gauges or transducers, of accuracy at least 0.5 kPa.

Note: If electronic pressure transducers are used with automated data capture, all operating requirements, including regular calibrations and checks should be adhered to.

e) Oxygen supply, of 99.8% purity (standard grade), and with a regulator capable of regulating pressure to 120 kPa.

- f) Vernier calliper, capable of reading to 0.02 mm.
- g) Desiccator, containing anhydrous silica gel as the desiccant, with the relative humidity controlled at a maximum of 60%.

2.3 TEST SPECIMENS

- a) Four specimens are required per test. Each specimen shall consist of a 70 ± 2 mm diameter concrete disc with a thickness of 30 ± 2 mm, cored and cut in accordance with Concrete Durability Index Testing Procedure Manual, Part 1.
- b) Mark the specimen(s) with a reference number (e.g. 1, 2, 3 and 4) on the interior face with a permanent marker.

2.4 CONDITIONING OF SPECIMENS

- a) Place the specimens in the oven, maintained at $50 \pm 2^\circ\text{C}$, for not less than 7 days and not more than 8 days. Allow sufficient space between and around specimens to ensure that they can dry uniformly.
- b) After the drying period, remove the specimens from the oven and immediately place them in the desiccator.
- c) Cool the specimens to $23 \pm 2^\circ\text{C}$ in the desiccator. Allow the specimens to cool for a minimum of 2 hours and a maximum of 4 hours. Remove the specimens from the desiccator and start the testing within 30 min.
- d) Measure and record, to an accuracy of 0.02 mm, the thickness and diameter of each specimen with the Vernier calliper at four points equally spaced around the perimeter of the specimen. Calculate and record, to the nearest 0.02 mm, the average of each set of four readings.

2.5 TESTING OF SPECIMENS

- a) Place the specimen in the compressible collar within the rigid sleeve with the exterior (test) face at the bottom. No gaps should be visible between the sides of the test specimen and the collar. The specimens shall be placed so that the interior face rests against the lip of the collar. See Figure 2.1 and Figure 2.3.

Note: The terms “exterior” and “interior” are used with respect to the position of the face of the specimen in the structure or the cube from which they were extracted. The provision of a “lip” (Figure 2.2) in the rubber collar is to ensure that the specimen is held in place tightly when it is subjected to pressure on the test face during the test.

- b) Place the sample, collar and rigid sleeve on top of the permeability cell so that they cover the hole. Place the solid ring (the solid ring is optional depending on the permeability cell arrangement) on top of the collar, ensuring that no gaps are visible between the collar and the sleeve. Place the cover plate on top of the solid ring. See Figure 2.3 and Figure 2.4.

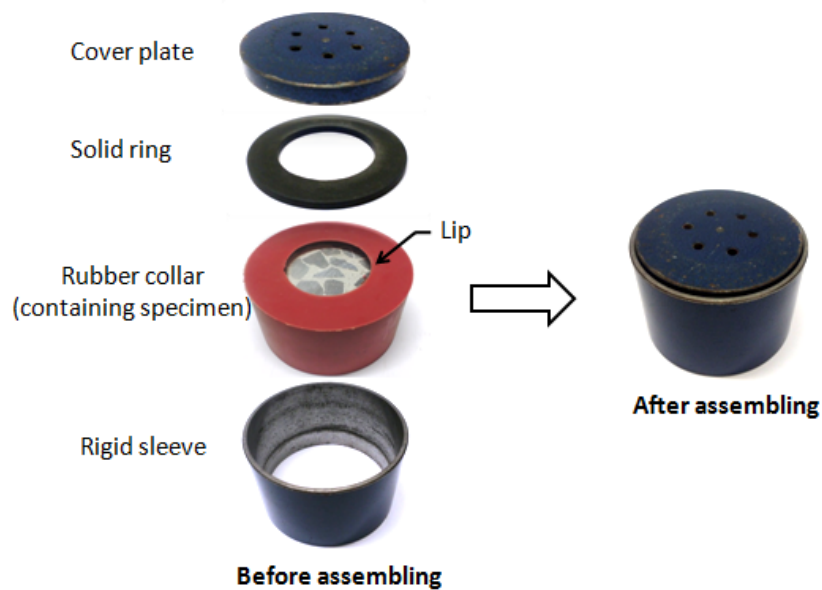

Figure 2.3: Different parts of the specimen assembly

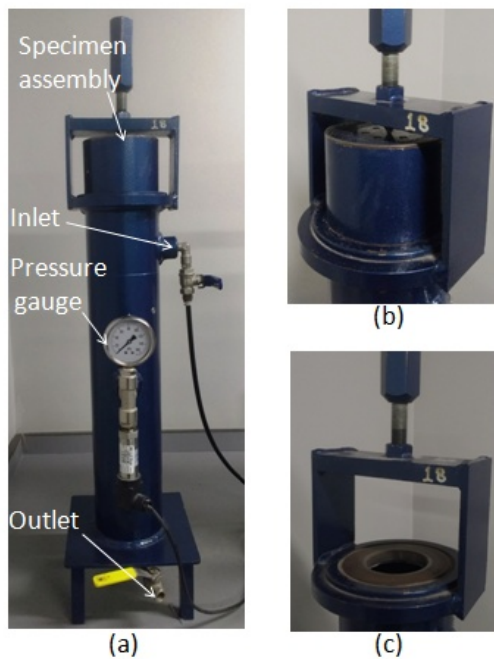

Figure 2.4: (a) Permeameter setup, (b) a close-up of specimen assembly, and (c) cell without specimen assembly

- c) Partially tighten the top screw on the cover plate to ensure that it is centred. Once the specimen has been centred, tighten the apparatus adequately to ensure no leakage of gas.

- d) Open the oxygen inlet and outlet valves of the permeability cell. Open the valve of the oxygen supply tank to between 100 and 120 kPa, and allow oxygen to flow through the permeameter cell for 5 seconds. This will purge the test chamber of gases other than oxygen.
- e) Close the outlet valve of the permeability cell, ensuring that there are no leaks.
- f) Increase the pressure in the permeability cell to 100 ± 5 kPa and close the inlet valve.
- g) After 5 min, record the time, t_0 , to the nearest minute, as the initial time, and initial exact pressure P_0 , to the nearest 0.5 kPa. Use t_0 and P_0 as such in the calculations. Thereafter, take at least eight readings at intervals corresponding to a pressure drop rate of 5 ± 1 kPa. A pressure drop of more than 5 kPa/min might be an indication of leakage. In such a case, release the pressure in the chamber, check that the sample fits tightly in the collar, and restart the test immediately, starting at paragraph (d).
- h) Terminate the testing when the pressure has dropped to 50 ± 2.5 kPa or after 6 hours ± 15 min, whichever occurs first. A minimum of 8 readings is required.

Note 1: It is possible to automate the readings. In this case, pressure readings shall be recorded by the data logging device at 15 minute intervals until the pressure drops to 50 ± 5 kPa or up to 6 hours ± 15 min, whichever occurs first. All the data points so generated shall be used in the calculation.

Note 2: Specimens can be re-tested if an obvious error in testing or measurement has been made. However, this should be within 30 min of the end of the initial test, to ensure that the moisture condition is not adversely affected.

- i) The same specimens that were used in the oxygen permeability test can also be used in the water sorptivity test. For details of the procedure, please refer to Part 3: 'Standard Procedure for Water Sorptivity and Porosity Test'.

2.6 CALCULATIONS

NOTE: A standard spreadsheet has been developed to perform the calculations described below, and it is strongly recommended that this spreadsheet be utilized. A copy of this spreadsheet is a free download from

<http://www.theconcreteinstitute.org.za/durability> in the 'Concrete Tools' Section.

Before commencing with permeability calculations, note that:

- (a) the pressure decay data should comprise pressure readings down to 50 kPa, and/or;
- (b) the maximum time duration for the test should not exceed 6 hours – see 2.5 h) above.

Any data (i.e. pressure readings and the corresponding times) falling outside these pressure and/or time limits should not be used in the permeability calculations.

- a) Determine the best fit line using linear regression of $\ln(P_0/P_t)$ against t and forcing the regression line through the (0,0) point where

t is the time since the start of the test, recorded to the nearest minute, in seconds;

P_0 is the initial pressure at start of test (at time t_0) to the nearest 0.5 kPa, in kilopascals (kPa);

P_t is the pressure reading at time t , measured from t_0 , to the nearest 0,5 kPa, in kilopascals (kPa).

- b) The coefficient of correlation (r^2) should be greater than 0.99. Where the correlation is less than 0.99 a re-test should be done on the same specimen. (If the conditions of Note 2 in 2.5 h) above cannot be met, place the specimen in the 50 °C oven overnight prior to cooling in the desiccator as per 2.4 (c) above, in order to re-test). If the subsequent test of the specimen also has a correlation coefficient of less than 0.99, this specimen should be discarded and another test specimen prepared.

Note 1: Every reading recorded as described in section 2.5 shall be used in the regression analysis. No data points shall be excluded in the determination of the correlation coefficient. No additional manipulation or exclusion of data points is allowed in order to improve the correlation coefficient. If the correlation coefficient is less than 0.99, the sample shall be re-tested.

Note 2: Notwithstanding Note 1 above, discretion should be exercised whether to always discard a specimen as above. It is possible to have very impermeable or alternatively very permeable specimens, where the r^2 may be less than 0.99, but will generally achieve 0.98.

Note 3: The slope of the linear regression line forced through the (0,0) point can be calculated from the equation (2.1):

$$z = \frac{\sum \left[\ln \left(\frac{P_0}{P_t} \right) \right]^2}{\sum \left[\ln \left(\frac{P_0}{P_t} \right) t \right]} \quad (2.1)$$

where

z is the slope of the linear regression;

P_0 , P_t , and t are defined as in 2.6 a).

- c) The correlation coefficient, r^2 , can be calculated from the equation (2.2):

$$r^2 = 1 - \frac{\sum [t_i - t_{p,i}]^2}{\sum t_i^2 - (\sum t_i)^2 / n} \quad (2.2)$$

where

t_i is the time at any given pressure reading, recorded to the nearest minute, in seconds (s);

$t_{p,i}$ is the predicted time at the same pressure reading (based on the linear regression), in seconds (s);

n is the number of data points being considered.

d) The value of $t_{p,i}$ can be calculated from:

$$t_{p,i} = \frac{\ln(P_0/P_t)}{z} \quad (2.3)$$

where P_0 , P_t and z are as defined above.

The 'slope' and 'rsq' functions available in Excel CANNOT be used, as they do not force the line through the zero point.

e) The D'arcy coefficient of permeability may be calculated from:

$$k = \frac{\omega \times V \times g \times d \times z}{R \times A \times T} \quad (2.4)$$

where

- k is the coefficient of permeability of the test specimen in metres per second (m/s);
 - ω is the molecular mass of oxygen (i.e., 0.032 kg/mol), in kilograms per mole (kg/mol);
 - V is the volume of the permeability cell, recorded to the nearest 0.01 litre or 0.00001 m³. The volume of the permeability cell includes the volume of the cell up to the lower face of the specimen. The volume shall be determined by dimensional measurement, accurate to the nearest mm, or by the volume of water contained at 23 ± 2 °C.
 - g is the gravitational acceleration (i.e., 9.81 m/s²), in metres per second squared (m/s²);
 - d is the average specimen thickness, to the nearest 0.02 mm, in metres (m);
 - z is the slope of the linear regression line forced through the (0,0) point, in reciprocal seconds (s⁻¹);
 - R is the universal gas constant (8.313 Nm/Kmol), in newton metres per Kelvin mole (Nm/Kmol);
 - A is the cross sectional area of the specimen, in square meters (m²);
 - T is the absolute temperature in Kelvin (K).
- f) The coefficient of permeability k is calculated for each specimen. The oxygen permeability index (OPI) shall be given as the average of the individual OPI values of the specimens (i.e., the geometric mean), which for four specimens is:

$$OPI = [(OPI_1 + OPI_2 + OPI_3 + OPI_4)/4] \quad (2.5)$$

where

OPI_i ($i = 1, 2, 3, 4$) is the calculated oxygen permeability index of the specimens, taken as the negative log of the k value, i.e.

$$OPI = -\log_{10}(k) \quad (2.6)$$

Where one specimen has been discarded, the coefficient of permeability may be calculated from the average of at least three valid test specimens using the following formula:

$$\text{OPI} = [(\text{OPI}_1 + \text{OPI}_2 + \text{OPI}_3) / 3] \quad (2.7)$$

Note: The repeatability and reproducibility of oxygen permeability testing are given in Appendix A.

2.7 REPORTING

The test report shall include the following information:

- a) The individual coefficient of permeability (k) of each specimen to three decimal places;
- b) The individual oxygen permeability index (OPI) of each specimen, to two decimal places;
- c) The average oxygen permeability index (OPI) of all specimens, to two decimal places;
- d) The identification mark of the specimens;
- e) A detailed description of the specimens, including flaws such as visible cracks, honeycombing defects or visible bleed paths. This is particularly important in this test since the test is stated to be indicative of macro-structural problems.

The test report shall also include the following information, if known:

- f) The source of the specimens;
- g) The location of the specimens (i.e., within the core or member);
- h) The type of concrete, including binder type, water/cement ratio and other relevant data supplied with the specimen;
- i) The curing history;
- j) A description of any unusual specimen preparation, for example, removal of surface treatment;
- k) A description of unusual features such as cracks, voids, and excessively chipped edges;
- l) The name of the test officer; and
- m) The age of concrete at time of testing.

2.8 REFERENCES

- (1) Alexander MG, Ballim Y, Mackechnie JM, 'Concrete durability index testing manual' Research Monograph No. 4, Departments of Civil Engineering, University of Cape Town and University of the Witwatersrand, March 1999

- (2) Mackechnie JR and Alexander MG, 'Practical considerations for rapid chloride conductivity testing.' Proceedings of the Second International RILEM Workshop on Testing and Modelling the Chloride Ingress Into Concrete, C. Andrade and J. Kropp, ed., 2000
- (3) Gouws SM, 'Durability index approach – method statements.' Document submitted to the Durability Index Test Method working group (Under the auspices of the C&CI Technical Committee), University of the Witwatersrand, 14 August 2003.
- (4) Gouws SM, 'Durability Index Approach – Progress Report 1: Method Statements' Summary document of major amendments to Durability Index Test Methods as agreed upon by Durability Index Test Method working group (Under the auspices of the C&CI Technical Committee, University of the Witwatersrand, 19 August 2003.
- (5) Gouws SM, 'Durability Index Approach – Progress Report 2: Method Statements' Summary document of major amendments to Durability Index Test Methods as agreed upon by Durability Index Test Method working group (Under the auspices of the C&CI Technical Committee, University of the Witwatersrand, 7 October 2003.
- (6) Mukadam Z, Alexander M.G., Beushausen H.D., 'The effects of drying preconditioning on the South African durability index tests.' Cement and Concrete Composites (69): 1-8, 2016.
- (7) Stanish, K., Alexander, M. G. and Ballim, Y., (2001), Assessing the repeatability and reproducibility values of South African durability index tests, SAICE Journal, Vol. 48(2), pp. 10-17.
- (8) ASTM C 802-14, 2014, "Standard Practice for Conducting an Inter-laboratory Test Program to Determine the Precision of Test Methods for Construction Materials," ASTM International.
- (9) ASTM C 670-90, 2015, "Standard Practice for Preparing Precision and Bias Statements for Test Methods for Construction Materials," ASTM International.

2.9 REVISIONS

Note: Revisions below may refer to older versions with different clause numbers to this version.

Revisions	Description	Date
A	For approval	8 April 2002
B	Indicated with subscript B	15 May 2002
C	K. Stanish (KS) – remove marked with strike through, added in bold, comments in italics	14 Feb 2003
C1	S. Gouws (SG) - suggested changes in red, questions and remarks in italics, see also reference 3	21 July 2003
D	For approval after Durability Index Test Method meeting on 19 August 2003, see also reference 4	19 August 2003
E	For approval after Durability Index Test Method meeting on 22 September 2003, see also ref. 5	22 September 2003
F	Editorial improvements and clarifications – M. G. Alexander (MGA)	April-July 2004

Revisions	Description	Date
G	KS – Clarification and illustration	April/May 2005
H	MGA - Definition of r^2 terms; addition of cell volume; Editorial Corrections	Jan/Oct 2007
I	MGA – Editorial and other corrections	Sep-Oct 2008
J	All MGA Cl. 5 b): addition of definition of 'z'. Cl. 5 c): insert 'to the nearest 0.02 mm' at end of definition of 'd' Cl. 6 a) replace 'significant figures' with 'decimal places'	25 Feb. 2009
K	SG as confirmed with MGA Cl. 1 b): added 'constructed not to expand at 100 to 120 kPa. Cl. 1g): removed the note 'not required if relative humidity in the laboratory is below 60%' Now only allowed to cool in desiccators. Cl. 3: added 'Remove the specimens from the oven and immediately place them in the desiccators.' Cl. 4 a): Removed the allowance of cooling in the laboratory, cooling may now only take place in the desiccators. Cl. 4 g): Added 'open the valve of the oxygen supply tank to between 100 and 120 kPa'. This is done so as not to open the tank to maximum pressure so as to protect the transducers. Cl. 5: Changed from UCT to C&CI's website. Cl. 5 b): Added the calculation of $t_{p,i}$ Cl. 5 c): Changed ω to 0.032 kg/mol instead of 32 g/mol and added that the temperature of the water must be $23 \pm 2^\circ\text{C}$.	May 2010
L	MGA & Chad Ludwig (CL) – Editorial changes; also to correspond to SANS 3001-CO3-2:2015 (OPI)	Oct – Nov 2016
M	MGA / MO. Changed 1s% to Coefficient of Variation (CoV), App A	12 July 2017
N	MGA / MO added sentence immediately under Cl. 2.6, re limits to test parameters when running calculations	14 July 2017
O	SS / MGA: Better clarity in Cl. 2.5, 2.6, including revised illustrations Figure 2.3, 2.4.	Dec. 2017/April 2018

APPENDIX A (Part 2)

Precision: Repeatability and reproducibility of oxygen permeability tests

Typical ranges of within test coefficient of variation and multi-laboratory precision are provided in table A.1. These values may be refined from time to time as additional data become available. These data derive mainly from inter-laboratory test programmes aimed at establishing repeatability and reproducibility data. In general, in excess of 30 test results were available.

Table A1: Guideline summary of repetability and reproducibility values

1	2	3
Repeatability and reproducibility	<i>k</i>-value	<i>OPI</i>
Repeatability (Coefficient of Variation (%))	CoV (%) ^a	CoV (%) ^a
Laboratory data	30 – 40	1,00 – 2,00
Ready mix concrete data	–	1,00 – 2,00
Site data	40 – 50	1,5 – 3,00
Reproducibility (Coefficient of Variation (%))	CoV (%) ^b	CoV (%) ^b
Laboratory data	30 – 50	1,00 – 3,00
^a Single operator coefficient of variation		
^b Between laboratory coefficient of variation		

APPENDIX B (Part 2)

Oxygen permeability index calculation

General

To illustrate the calculations given in Clause 2.6, typical calculations are given below to determine the oxygen permeability index. All variables are as defined in 2.6 a) to e).

Calculations

- a) Illustrative time and pressure readings of four specimens that were obtained from the same concrete are shown in table B.1, truncated for brevity, and dimensions are given in table B.2. The calculation of z for specimen 1 is shown in table B.3 and b).

Table B.1: Time and pressure readings of specimens

1	2	3	4	5	6	7	8
Specimen number							
1		2		3		4	
Actual time hh.mm.ss	Pressure P_t kPa	Actual time hh.mm.ss	Pressure P_t kPa	Actual time hh.mm.ss	Pressure P_t kPa	Actual time hh.mm.ss	Pressure P_t kPa
12:55:00	100,0	10:12:00	100,0	14:01:00	100,0	14:00:00	100,0
13:01:00	96,0	10:17:00	97,0	14:03:00	98,5	14:03:00	98,0
13:05:00	93,0	10:22:00	92,0	14:06:00	95,5	14:06:00	96,0
13:09:00	90,0	10:25:00	89,5	14:09:00	93,5	14:09:00	94,0
13:18:00	85,0	10:32:00	84,5	14:13:00	92,5	14:13:00	90,0
13:24:00	80,0	10:39:00	80,0	14:16:00	91,0	14:16:00	88,0
13:28:00	78,0	10:46:00	77,5	14:19:00	87,0	14:19:00	86,0
13:34:00	74,0	10:53:00	74,5	14:23:00	85,0	14:23:00	84,0
13:38:00	72,0	10:57:00	70,0	14:26:00	82,5	14:27:00	81,0
13:42:00	70,0	11:05:00	67,0	14:31:00	80,0	14:31:00	79,0
13:48:00	67,0	11:12:00	64,0	14:34:00	78,0	14:36:00	75,0
13:54:00	65,0	11:18:00	62,0	14:37:00	76,0	14:41:00	73,0

Table B.2: Dimensions of the specimens and parameters used

1	2	3	4	5	6
Parameter	Measurement	Specimen number			
		1	2	3	4
Thickness d $m \times 10^{-2}$	1	3,16	3,02	2,90	3,06
	2	3,06	3,08	2,98	3,02
	3	3,16	3,10	2,94	3,08
	4	3,06	3,00	3,00	3,02
	average	3,11	3,05	2,96	3,05
Diameter $m \times 10^{-2}$	1	6,92	6,94	6,90	6,96
	2	6,96	6,96	6,92	6,94
	3	6,98	6,92	6,94	6,94
	4	6,90	6,98	6,86	6,98
	average	6,94	6,95	6,91	6,96
Cross-sectional area A $m^2 \times 10^{-3}$		3,78	3,79	3,75	3,81
Volume of permeability cell V $m^3 \times 10^{-3}$		4,90	4,95	4,83	4,90

Table B.3: Calculation of z for specimen 1

1	2	3	4	5	6	7
Actual time hh.mm.ss	Time since start of test, t s	Pressure, P_t kPa	P_0/P_t	$\ln(P_0/P_t)$	$[\ln(P_0/P_t)]^2$	$\ln(P_0/P_t) \times t$
12:55:00	0	100,0	1,000	0,000	0,000	0,000
13:01:00	360	96,0	1,042	0,041	0,002	14,760
13:05:00	600	93,0	1,075	0,072	0,005	43,200
13:09:00	840	90,0	1,111	0,105	0,011	88,200
13:18:00	1 380	85,0	1,176	0,162	0,026	223,560
13:24:00	1 740	80,0	1,250	0,223	0,050	388, 020
13:28:00	1 980	78,0	1,282	0,248	0,062	491,040
13:34:00	2 340	74,0	1,351	0,301	0,091	704,340
13:38:00	2 580	72,0	1,389	0,329	0,108	848,820
13:42:00	2 820	70,0	1,429	0,357	0,127	1 006,740
13:48:00	3 180	67,0	1,493	0,401	0,161	1 275,180
13:54:00	3 540	65,0	1,538	0,430	0,185	1 522,200

b) The slope of the linear regression line of specimen 1, forced through the (0,0) point may be calculated as follows:

$$z = \frac{\sum \left[\ln \left(\frac{P_0}{P_t} \right) \right]^2}{\sum \left[\ln \left(\frac{P_0}{P_t} \right) \times t \right]}$$

From Table B.3: $\sum \left[\ln \left(\frac{P_0}{P_t} \right) \right]^2 = 0.828$

Therefore $\sum \left[\ln \left(\frac{P_0}{P_t} \right) \times t \right] = 6606.060$

Therefore $z = \frac{0.828}{6606.060}$

$$z = 0.000125$$

c) The calculation of the correlation coefficient, r^2 , of the linear regression line of specimen 1, forced through (0,0) is shown in Table B.4 and d).

Table B.4: Calculation of r^2 for specimen 1

1	2	3	4	5	6	7	8	9
Actual time hh.mm.ss	Time since start of test, t s	Pressure P_t kPa	P_0/P_t	$\ln(P_0/P_t)$	$t_{p,i}$ [$\ln(P_0/P_t)/z$]	$t_i - t_{p,i}$	$(t_i - t_{p,i})^2$	t_i^2
12:55:00	0	100,0	1,000	0,000	0,000	0,000	0,000	0
13:01:00	360	96,0	1,042	0,041	328	320	1 024	129 600
13:05:00	600	93,0	1,075	0,072	576	24	576	360 000
13:09:00	840	90,0	1,111	0,105	840	0	0	705 600
13:18:00	1 380	85,0	1,176	0,162	1 296	84	7 056	1 904 400
13:24:00	1 740	80,0	1,250	0,223	1 784	-44	1 936	3 027 600
13:28:00	1 980	78,0	1,282	0,248	1 984	-4	16	3 920 400
13:34:00	2 340	74,0	1,351	0,301	2 408	-68	4 624	5 475 600
13:38:00	2 580	72,0	1,389	0,329	2 632	-52	2 704	6 656 400
13:42:00	2 820	70,0	1,429	0,357	2 856	-36	1 296	7 952 400
13:48:00	3 180	67,0	1,493	0,401	3 208	-28	784	10 112 400

1	2	3	4	5	6	7	8	9
Actual time hh.mm.ss	Time since start of test, t s	Pressure P_t kPa	P_0/P_t	$\ln(P_0/P_t)$	$t_{p,i}$ [$\ln(P_0/P_t)/z$]	$t_i - t_{p,i}$	$(t_i - t_{p,i})^2$	t_i^2
13:54:00	3 540	65,0	1,538	0,430	3 440	96	9 216	12 531 600

d) The value of r^2 may be calculated as follows:

$$r^2 = 1 - \frac{\sum [t_i - t_{p,i}]^2}{\sum t_i^2 - (\sum t_i)^2 / n}$$

$$t_{p,i} = \frac{\ln\left(\frac{P_0}{P_t}\right)}{z}$$

Therefore, from Table B.4

$$\sum [t_i - t_{p,i}]^2 = 29\,232$$

$$\sum t_i^2 = 52\,776\,000$$

$$\sum t_i = 21\,360$$

$$n = 12$$

Therefore

$$\frac{(\sum t_i)^2}{n} = 38\,020\,800$$

Therefore

$$r^2 = 1 - \frac{29232}{52776000 - 38020800}$$

Therefore

$$r^2 = 0.998$$

Since $r^2 \geq 0.99$, it is not necessary to re-test the specimen.

e) The value of k for specimen 1 can then be calculated as follows:

$$k = \frac{\omega \times V \times g \times d \times z}{R \times A \times T}$$

Where

ω is the molecular mass of oxygen, = 0,032 kg/mol;

V is the volume of oxygen under pressure in the tank in which specimen 1 was tested, = 4,9L = 0,0049 m³;

g is the gravitational acceleration, = 9,81 m/s²;

R is the universal gas constant, = 8,313 Nm/K mol;

d is the average thickness of specimen 1, measured at four different positions, = 31.1 mm = 0,0311 m;

A is the cross-sectional area of specimen 1, calculated from the diameter measured at four positions, $A = 0,00378$ m²;

T is the temperature in kelvins, = 296,15 K;

z is the slope of the linear regression line, = 0,000125 s⁻¹, therefore

$$k = \frac{0.032 \times 0.0049 \times 9.81 \times 0.0311 \times 0.000125}{8.313 \times 0.00378 \times 296.15}$$

Therefore

$$k = 6.426 \times 10^{-10} \text{ m/s}$$

f) The coefficient of permeability, k_i , (m/s) of each of the other four specimens is calculated in a similar fashion for each specimen resulting in the following values.

$$k_1 = 6,426 \times 10^{-10} \text{ m/s} \quad OPI = 9,19$$

$$k_2 = 6,370 \times 10^{-10} \text{ m/s} \quad OPI = 9,20$$

$$k_3 = 6,074 \times 10^{-10} \text{ m/s} \quad OPI = 9,22$$

$$k_4 = 6,474 \times 10^{-10} \text{ m/s} \quad OPI = 9,19$$

g) The average oxygen permeability index is calculated as follows:

$$OPI = [(OPI_1 + OPI_2 + OPI_3 + OPI_4)/4]$$

$$OPI = 9,20$$

CONCRETE DURABILITY INDEX TESTING MANUAL

PART 3: STANDARD PROCEDURE FOR WATER SORPTIVITY AND POROSITY TEST

3.1 SCOPE

This test method sets out the procedure for determining the water sorptivity index as originally described by Alexander, Ballim and Mackechnie ⁽¹⁾. The method described herein supersedes the 1999 version in ref. 1. The test also allows determination of the water-penetrable porosity of the specimen, which is important in interpreting the water sorptivity value.

The test is suitable for the evaluation of materials and mix proportions for design purposes, and for research and development. The test can also be used for quality control of concrete on site. It is not recommended that this test be performed before 28 days after casting. Specimen age may have a significant effect on the test results, depending on the type of concrete and the curing procedure. Care should be taken in interpreting the results of this test when it is used on surface treated concretes, or on concrete that has been exposed to environmental influences such as carbonation or marine salts.

The oven drying procedure has been selected to result in a minimal degree of micro-structural alteration of the concrete specimens, while still giving minimal uniform moisture content. Research has shown, however, that significant amounts of micro-structural damage may occur for high quality concrete⁽²⁾. Thus care should be taken in interpreting the test results from these concretes.

This test method shall not be used for concrete with a maximum nominal aggregate size exceeding 26.5 mm.

3.2 APPARATUS

- a) An oven capable of maintaining a temperature of $50 \pm 2^{\circ}\text{C}$.

Note: Most lab ovens are of the forced draft, ventilated type. If, however, the oven being used is of the closed (unventilated) type, then the relative humidity inside the oven must be maintained by the inclusion of trays of saturated calcium chloride solution. The trays should provide a total exposed area of at least 1 m^2 per 1 m^3 of volume of the oven and should contain sufficient solid calcium chloride to show above the surface of the solution throughout the test.

- b) Vacuum saturation facility as shown in Figure 3.1.
- c) Plastic or stainless steel tray 20 mm deep and large enough to hold as many specimens as will be tested simultaneously.
- d) Ten layers of absorbent paper towel. Alternatively, 2 small rollers or 4 pins can be used to support the specimens tested.
- e) Vernier calliper, capable of reading to 0,02 mm.
- f) Measuring scale with accuracy to 0.01 g.
- g) A solution of tap water saturated with calcium hydroxide, (3 grams of $\text{Ca}(\text{OH})_2$ per 1 litre of water), maintained at $23 \pm 2^{\circ}\text{C}$.

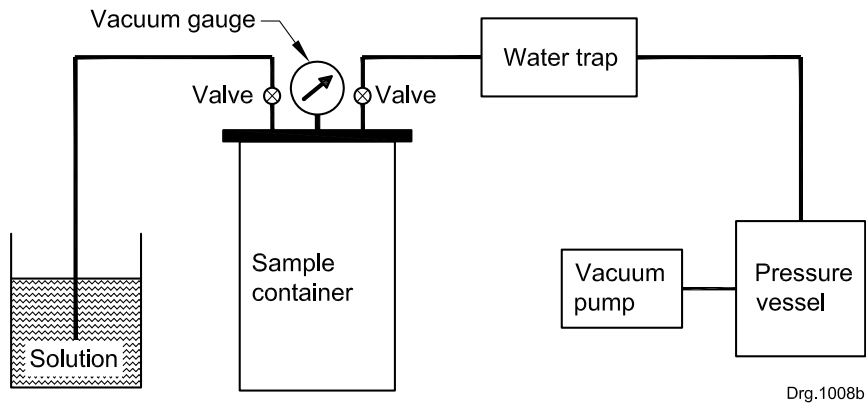

Figure 3.1: Vacuum Saturation Facility

- h) One or more stopwatches as required.
- i) Sealant to provide a watertight seal around the curved edges of the specimens without blocking any part of the test face whatsoever. A suitable method of sealing is the use of packaging tape.
- j) Desiccator, large enough to hold as many specimens as will be tested simultaneously, containing anhydrous silica gel as the desiccant, with the relative humidity controlled at a maximum of 60 %.

3.3 TEST SPECIMENS

- a) Four specimens are required per test. Each specimen shall consist of a 70 ± 2 mm diameter concrete disc with a thickness of 30 ± 2 mm, cored and cut in accordance with Concrete Durability Index Testing Procedure Manual, Part 1. It is permitted to use specimens that have previously been used in the oxygen permeability test, provided they have not been exposed to moisture. Refer to Part 2: 'Standard Procedure for Oxygen Permeability Test'.
- b) Mark the specimens of the same reference 1, 2, 3 and 4 on the inner face.

3.4 CONDITIONING OF SPECIMENS

- a) If using new specimens directly after cutting, the specimens shall be placed in the oven at 50 ± 2 °C for not less than 7 days and not more than 8 days.
- b) After the drying period, remove the specimens from the oven and immediately place them in the desiccator.
- c) Cool the specimens to 23 ± 2 °C in the desiccator. Allow the specimens to cool for a minimum of 2 hours and a maximum of 4 hours. Remove the specimens from the desiccator and start the testing within 30 min.
- d) Measure to the nearest 0.02 mm the thickness and diameter of each specimen with the Vernier calliper at 4 points equally spaced around the perimeter of the specimen, and record. Determine the average of the four readings and record to the nearest 0.02 mm.

- e) Seal the curved sides of the specimens using a sealant as detailed in 3.2 i) above.
- f) If the specimens have been previously tested in the oxygen permeability cells, they shall be tested immediately upon removal. No additional drying is necessary provided the specimens have not got wet or have not had an opportunity to absorb moisture from the atmosphere. Alternatively, specimens may be placed back in the 50 °C oven overnight prior to cooling in the desiccator as per 3.4 (c) above, if they cannot be tested immediately after the OPI test.

3.5 TESTING OF SPECIMENS

- a) The water sorptivity test shall be conducted in a room in which the temperature is controlled at 23 ± 2 °C.
- b) Place the 10 layers of paper towel in the tray. Alternatively, place the rollers/pins in position to support the specimen in the solution.
- c) Pour calcium hydroxide solution into the tray. If used, the paper towels should be saturated with water visible on the top surface. All air bubbles should be removed by smoothing the paper pad towards the edges, see Figure 3.2. If rollers or pins are used, they should be arranged so as to support the specimens and the calcium hydroxide solution should be above the top of the support, Figure 3.3. The final water level should be such that it will be slightly above the bottom edge of the specimen and a maximum 2 mm up the side of the specimen as shown in Figure 3.4. Dampen an additional piece of paper towel for use in removing the excess water from the specimens (in paragraph (g)) and keep next to the tray to be used during the test.

NOTE: Rollers or pins, if used, should be sufficiently small so as not materially to affect the area of specimen surface exposed to the solution.

- d) Within 30 min after removing the specimen from the desiccator, or oxygen permeability cell, determine the mass of the specimen to an accuracy of 0.01 g and record as the dry mass, M_{s0} . This mass must be determined after the method used to seal the sides of the specimens.
- e) Immediately place the specimen with the test face (outer face or originally exposed face) on the wet paper pad/pins/rollers and start the stopwatch, at time t_0 .
- f) Weigh the specimen at 3, 5, 7, 9, 12, 16, 20 and 25 minutes, after patting it once on the damp piece of absorbent paper. The specimen should appear saturated surface dry (SSD) on the exposed face at the time the mass is determined, i.e. it should look damp, but not have free water on the test face. During removal of a specimen from the tray for weighing, care must be taken to prevent dripping from one specimen onto the top of another.
- g) Record the mass of the specimen to the nearest 0.01 g within 10 s of removal of the specimen from the tray and wiping excess water. Replace the specimens each time with the test face on the wet paper or rollers/pins if used. The stopwatch shall not be stopped during the weighing procedure.

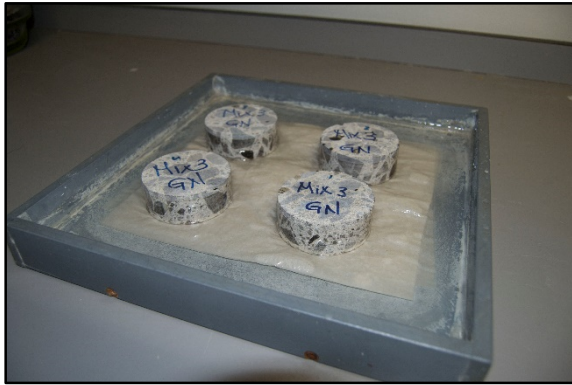

Figure 3.2: Test setup using paper towels

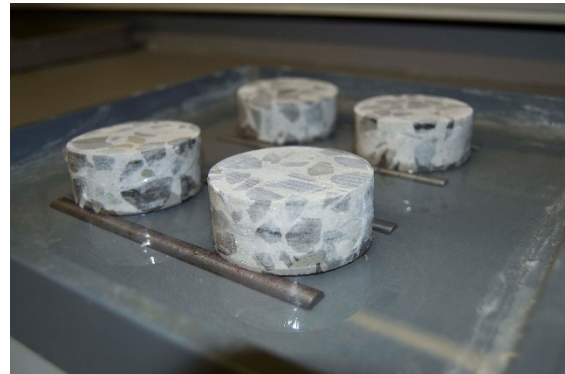

Figure 3.3: Test setup using supports



Figure 3.4: Proper solution depth

- h) Within a maximum of 1 day after weighing of the specimen is completed, place the specimen in the vacuum saturation tank. The tape or sealant must be left in place. The specimens shall be arranged so as to maximize their exposed surface area. This is typically done by standing the individual specimens upon their curved edges, rather than the flat side, as in Figure 3.5. Seal the lid with petroleum jelly and close it.
- i) Evacuate the tank to between -75 and -80 kPa and maintain the specimens under vacuum of between -75 and -80 kPa for 3 hours \pm 15 min. The pressure must not be allowed to rise above -75 kPa during this period.
- j) After 3 hours \pm 15 min isolate the tank and allow calcium hydroxide saturated water to flow into the chamber until the water level is approximately 40 mm above the top of the specimens. Air shall not be allowed to enter the vacuum chamber during this procedure.



Figure 3.5: Illustration of recommended arrangement of specimens for saturation

- k) Re-establish the vacuum to between -75 and -80 kPa. This shall be maintained for 1 hour \pm 15 minutes. At no point during this time period shall the vacuum be permitted to rise above -75 kPa.
- l) After 1 hour \pm 15 min, release the vacuum and allow air to enter. Allow the specimens to soak for a further 18 \pm 1 hours.
- m) After 18 \pm 1 hr soaking, remove the specimens from the solution, dry the surface to a SSD condition with a paper towel, and immediately weigh to an accuracy of 0.01 g. Record this as the vacuum saturated mass M_{sv} of the specimen.

3.6 CALCULATIONS

NOTE: A standard spreadsheet has been developed to perform the calculations described below, and it is strongly recommended that this spreadsheet be utilized. A copy of this spreadsheet is a free download from <http://www.theconcreteinstitute.org.za/durability> in the 'Concrete Tools' Section.

- a) Determine the porosity (n) of each specimen, as a percentage, by applying the following formula:

$$n = \frac{M_{sv} - M_{s0}}{A d \rho_w} \times 100 \quad (3.1)$$

where

M_{sv} is the vacuum saturated mass of the specimen to the nearest 0.01g, in grams

M_{s0} is the mass of the specimen at time t_0 (start of the test) to the nearest 0.01g, in grams

A is the cross-sectional area of the specimen to the nearest 0,02 mm² in millimetres squared

- d is the average specimen thickness to the nearest 0,02 mm, in millimetres
- ρ_w is the density of water, 10^{-3} g/mm³, in grams per millimetres cubed

- b) Determine and plot the mass gain (M_{wt}) versus the square root of time, by applying the following formula:

$$M_{wt} = F\sqrt{t} \quad (3.2)$$

where

- F is the slope of the best fit line from plotting M_{wt} against square root of hour, in grams
- t is the time in hours after a specimen was first exposed to water on its lower face, to the nearest 0.001 h, in hours

Use the following equation to determine the mass gain (M_{wti}):

$$M_{wti} = M_{st} - M_{s0} \quad (3.3)$$

where

- M_{st} is the mass to the nearest 0,01g of the specimen at particular time t, in grams
- M_{s0} is the mass to the nearest 0.01g of the specimen at the initial time (t_0), in grams.

Note: No allowance shall be made for the time taken to wipe and weigh each sample in the calculation.

Do not include the zero time reading in the data.

- c) Determine the correlation coefficient, r^2 of the data:

$$r^2 = \left[\frac{\sum (\sqrt{t_i} - T)(M_{wti} - \bar{M}_{wt})}{\sqrt{\sum (\sqrt{t_i} - T)^2 \sum (M_{wti} - \bar{M}_{wt})^2}} \right]^2 \quad (3.4)$$

where

- M_{wti} is the mass gain as calculated in 3.6 b) at any given time, in grams
- t_i is the time corresponding to the mass gain M_{wti} , in hours

and

$$\bar{M}_{wt} = \frac{\sum M_{wti}}{n} \quad (3.5)$$

and

$$T = \frac{\sum \sqrt{t_i}}{n} \quad (3.6)$$

where

n is the number of data points.

- d) If the coefficient of correlation is less than 0,98, discard the last (25 min) value from the analysis, and re-determine the correlation coefficient, adjusting the value of n, the number of data points, in the calculation as relevant.
- e) If the coefficient of correlation is still less than 0,98, discard the next value (i.e. 20 min) from the analysis, and re-determine the correlation coefficient, adjusting the value of n, the number of data points, in the calculation as relevant.
- f) Repeat the procedure until a coefficient of above 0,98 is achieved, or there are less than 5 data points remaining.
- g) If a correlation coefficient of 0,98 cannot be obtained with a set of five or more values, regard the specimen as unsuitable for the determination of the sorptivity. However, record the range of data able to give a correlation coefficient of above 0,98.
- h) Using the values obtained from procedures contained in c) to f) (inclusive), determine the slope of the line of best fit (F) by linear regression analysis:

$$F = \frac{\sum (\sqrt{t_i} - T)(M_{wti} - \bar{M}_{wt})}{\sum (\sqrt{t_i} - T)^2} \quad (3.7)$$

where

M_{wti} is the mass gain as calculated in 3.6 b) at any given time, in grams, equation (3.3).

t_i is the time corresponding to the mass gain reading M_{wti} , in hours and

\bar{M}_{wt} and T are given in equations (3.5) and (3.6) respectively.

- i) The water sorptivity of the specimen (S), in mm/ \sqrt{h} , is given by:

$$S = \frac{Fd}{M_{sv} - M_{s0}} \quad (3.8)$$

where

F is the slope of the best fit line (equation (3.7)), in grams per square root of hour

d is the average specimen thickness to the nearest 0,02 mm, in mm

M_{sv} is the vacuum saturated mass to the nearest 0,01 g of the specimen, in grams

M_{s0} is the mass to the nearest 0,01 g of the specimen at the initial time (t_0), in grams

- j) The procedure 3.6 a) through 3.5 g) is carried out separately for each specimen. The sorptivity index is given as the average of the water sorptivity of the valid individual test determinations.⁽⁴⁾

Note: Where one specimen has been deemed unsuitable in 3.6 g), it should not be used in determining the average water sorptivity. At least three valid test specimens should be used to determine the average water sorptivity.

Note: A simple way to calculate the slope of the regression line is by entering the data in a Microsoft Excel range and use the function SLOPE {data range of M_{wt_i} ; data range \sqrt{t} }. The correlation coefficient can be obtained by using the RSQ {data range M_{wt_i} ; data range of \sqrt{t} } function.

3.7 REPORTING

Report the following:

- a) Identification number of specimen.
- b) Description of specimen.
- c) The porosity of each specimen (in percent) to the nearest 1 decimal place.
- d) The water sorptivity of each individual specimen (in mm/ \sqrt{h}), to the nearest 1 decimal place.
- e) The water sorptivity index (in mm/ \sqrt{h}) to the nearest 1 decimal place.
- f) The range of data used in the calculations.

The following shall also be reported if known

- g) Source of the specimen.
- h) Location of specimen within cube, core or member
- i) Identification mark of each specimen
- j) Type of concrete, including binder type, water/cement ratio and other relevant data supplied with the specimen.
- k) Curing history.
- l) Unusual specimen preparation e.g. removal of surface treatment.
- m) Unusual features such as cracks, voids, excessively chipped edges, etc.
- n) Test operator.
- o) Age of concrete at time of testing.

Note on interpretation of test values for water sorptivity (WS) and porosity: The measured values of water sorptivity and porosity are inter-related. For example, a low WS value may be due to a high porosity value, and vice versa (although this is not always the case). Therefore, care should be taken in reporting and interpreting these values.

3.8 REFERENCES

- (1) Alexander M.G., Ballim Y., Mackechnie J.M., 'Concrete durability index testing manual' Research Monograph no. 4, Departments of Civil Engineering, University of Cape Town and University of the Witwatersrand, March 1999
- (2) Mackechnie JR and Alexander MG, 'Practical considerations for rapid chloride conductivity testing.' Proceedings of the Second International Workshop on Testing and Modelling the Chloride Ingress Into Concrete,
- (3) Nilsson L.O., Andersen A, Luping T, 'Chloride Ingress Data from Field Exposure in a Swedish Environment', Proc. 2nd International RILEM Workshop "Testing and Modelling the Chloride Ingress into Concrete", Eds Andrade C, Kropp J, Paris, 11-12 September 2000.
- (4) Gouws SM, 'Durability index approach – method statements.' Document submitted to the Durability Index Test Method working group (Under the auspices of the C&CI Technical Committee), University of the Witwatersrand, 14 August 2003.
- (5) Gouws SM, 'Durability Index Approach – Progress Report 1: Method Statements' Summary document of major amendments to Durability Index Test Methods as agreed upon by Durability Index Test Method working group (Under the auspices of the C&CI Technical Committee, University of the Witwatersrand, 19 August 2003.
- (6) Gouws SM, 'Durability Index Approach – Progress Report 2: Method Statements' Summary document of major amendments to Durability Index Test Methods as agreed upon by Durability Index Test Method working group (Under the auspices of the C&CI Technical Committee, University of the Witwatersrand, 7 October 2003.
- (7) Mukadam Z, Alexander M.G., Beushausen H.D., 'The effects of drying preconditioning on the South African durability index tests.' Cement and Concrete Composites (69): 1-8, 2016.

3.9 REVISIONS

Note: Revisions below may refer to older versions with different clause numbers to this version.

Revisions	Description	Date
A	For approval	8 April 2002
B	Indicated with subscript B	15 May 2002
C	K. Stanish (KS) – remove marked with strike through, added in bold, comments in italics	14 Feb 2003
C1	S. Gouws (SG) - suggested changes in red, <i>questions and remarks in italics</i> , see also reference 4	21 July 2003
D	For approval after Durability Index Test Method meeting on 19 August 2003, see also reference 5	19 August 2003
E	For approval after Durability Index Test Method meeting on 22 September 2003, see also reference 6	22 September 2003
F	Editorial improvements and clarifications – M. G. Alexander	April-July 2004

Revisions	Description	Date
	(MGA)	
G	KS – Clarification and illustration	April/May 2005
H	MGA - Definition of r^2 terms; addition of cell volume; Editorial Corrections	Jan/Oct 2007
I	MGA – Editorial and other corrections	Sep-Oct 2008
J	All MGA Cl. 1 e) Accuracy of Vernier inserted Cl. 5 h) Added definitions of F, d, M_{sv} , and M_{s0} . Cl. 6 c) Changes accuracy to 2 decimal places	25 Feb. 2009
K	SG as confirmed with MGA Cl.1 i), 3 b), 4 f): Removed all references to epoxy paint Cl. 1 k): Must use desiccator for cooling Cl. 3 a): Added 'if using new specimens' Cl. 3 b): Added 'remove the specimens from the oven' Cl. 3 c): Added 'oven at 50 °C' and 'as per part 2' Cl. 4 b): Must use desiccator for cooling Cl. 4 e): Moved 'at time to' to the end of 4 f) Cl. 5 a): Changed from UCT's website to C&CI's website Cl. 5 c): Added 'use only relevant number of data points for n'	May 2010
L	MGA & Chad Ludwig (CL) – Editorial changes	Oct-Nov 2016
M	SS/ MO/ MGA – Amount of CH required to make saturated solution changed from 5 g to 3 g	Dec 2017

CONCRETE DURABILITY INDEX TESTING MANUAL

PART 4: STANDARD PROCEDURE FOR CHLORIDE CONDUCTIVITY TEST

4.1 SCOPE

This test method sets out the procedure for determining the chloride conductivity index as originally described by Alexander, Ballim and Mackechnie⁽¹⁾. The method described herein supersedes the 1999 version in ref. 1.

The test is suitable for the evaluation of materials and mix proportions for design purposes and for research and development. The test can also be used for quality control of concrete on site. Specimen age may have a significant effect on the test results, depending on the type of concrete and the curing procedure. Care should be taken in interpreting the results of this test when it is used on surface treated concretes. In general, the test should not be performed on concrete that has been exposed to environmental influences such as carbonation or marine salts.

The oven drying procedure has been selected to result in a minimal degree of micro-structural alteration of the concrete specimens, while still resulting in minimal uniform moisture content. Research has shown, however, that significant amounts of micro-structural damage may occur for some high quality concrete⁽²⁾. Thus care should be taken in interpreting the test results from these concretes.

Since the test results are a function of the electrical resistance of the specimen, the presence of reinforcing steel or other embedded electrically conductive material may have a significant effect. Likewise, admixtures or concrete additives such as those containing nitrites may also affect the conductivity of the specimen.

This test method shall not be used for concrete with a maximum nominal aggregate size exceeding 26.5 mm.

Care should be taken when performing this test, since the chloride solution used is hazardous to the skin. It is recommended that gloves be used.

4.2 APPARATUS

- a) An oven capable of maintaining a temperature of $50 \pm 2^{\circ}\text{C}$.

Note: Most lab ovens are of the forced draft, ventilated type. If, however, the oven being used is of the closed (unventilated) type, then the relative humidity inside the oven must be maintained by the inclusion of trays of saturated calcium chloride solution. The trays should provide a total exposed area of at least 1 m^2 per 1 m^3 of volume of the oven and should contain sufficient solid calcium chloride to show above the surface of the solution throughout the test.

- b) Vacuum saturation facility as shown in Figure 3.1, Part 3.
- c) Conduction cell as shown in Figure 4.1 with anode and cathode parts permanently marked on the outside of the cell, and with flexible rubber collars free of cracks or tears.

Note: Two designs of the conduction cell are available (see Figures 4.1 a) and b))

- d) Stabilized DC power supply, 0 V to 12 V, 0 A to 1 A.

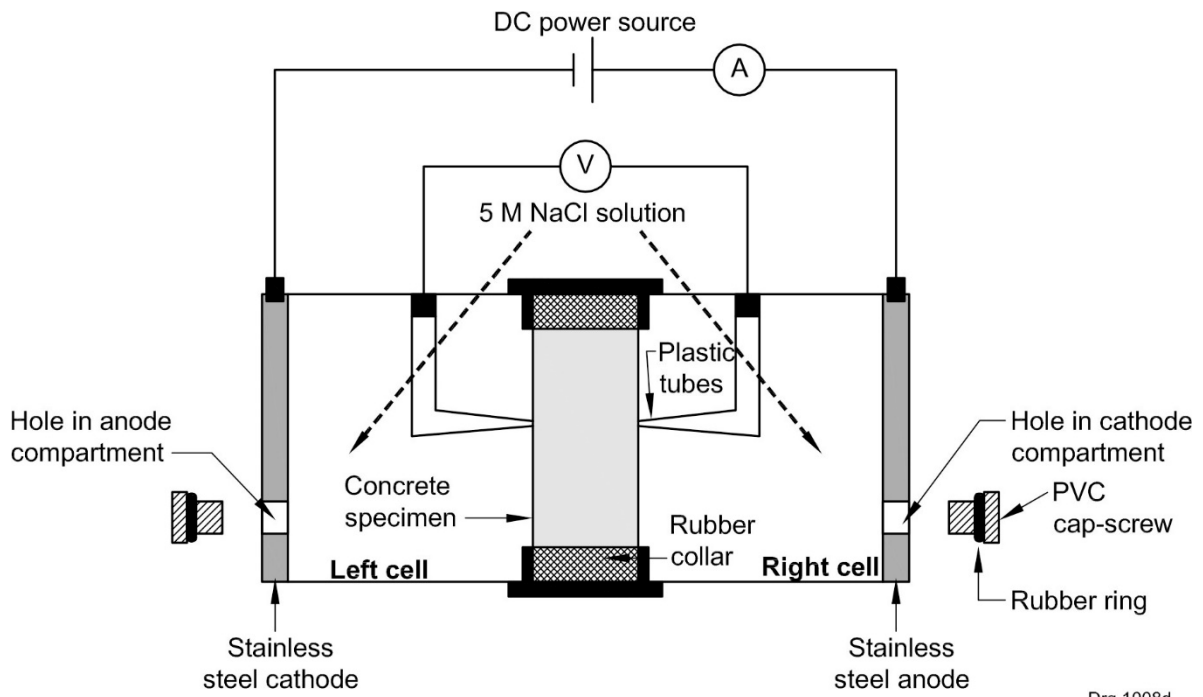

a) Simple cell arrangement

Drg.1008d

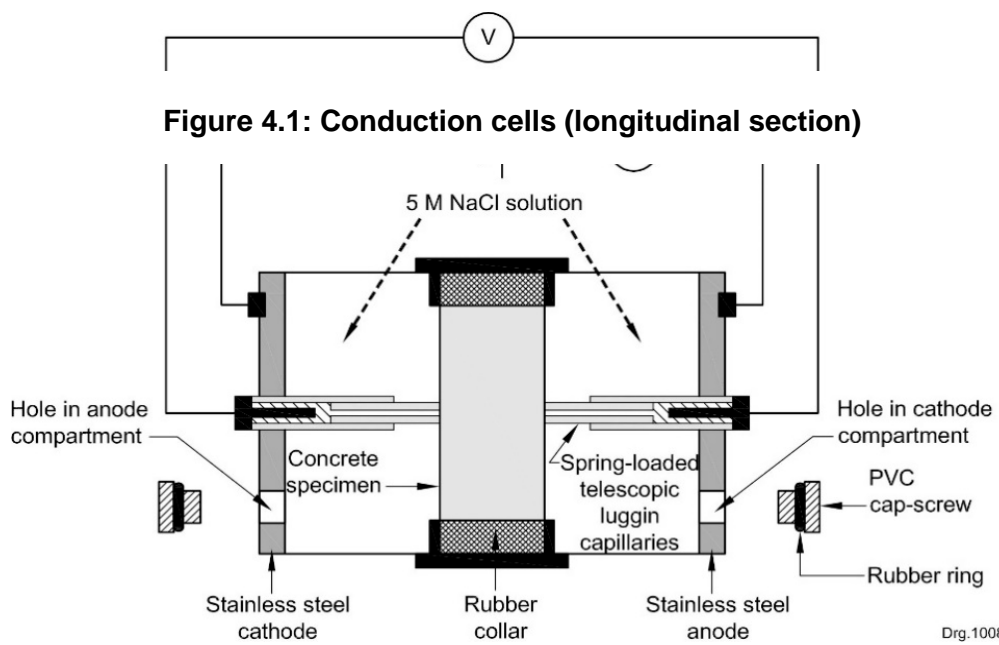

Figure 4.1: Conduction cells (longitudinal section)

b) Telescopic tube arrangement

Drg.1008e

- e) Digital voltmeter and ammeter (two multimeters), capable of displaying four-digits, 0 V to 20 V range, 0 mA to 300 mA, and a rated accuracy of 0.1 %.
- f) Measuring scale, of accuracy at least 0.01 g.
- g) Vernier calliper, capable of reading to 0.02 mm.
- h) CP grade NaCl, of 99% purity.
- i) Desiccator, containing anhydrous silica gel as the desiccant, with the relative humidity controlled at a maximum of 60 %.

Note: Due to the highly corrosive solutions used during the test, all equipment must be cleaned thoroughly with warm soapy water after each use. The copper electrodes and banana plugs need to be cleaned with sandpaper or an acidic solution. Replacement electrical connections are necessary from time to time. To protect electrical test equipment, it is advisable to place such equipment on a shelf above the bench on which the conductivity cell is placed.

4.3 PREPARATION OF THE CHEMICAL SOLUTION (5M NaCl)

- a) Add 2.93 kg of NaCl (salt) to a container large enough to contain more than 10 L of water.
- b) Add 10 L of potable water.
- c) Stir until the salt has dissolved.
- d) Seal the container of 5M sodium chloride solution, and store for at least 1 day at a temperature of 23 ± 2 °C.

4.4 TEST SPECIMENS

- a) Four specimens are required per test. The test specimen shall consist of a 70 ± 2 mm diameter concrete disc with a thickness of 30 ± 2 mm cored and cut in accordance with the Concrete Durability Index Testing Procedure Manual, Part 1.
- b) Mark the specimens of the same reference 1, 2, 3 and 4 on the inner face.

4.5 CONDITIONING OF SPECIMENS

- a) Place the specimens in the oven, maintained at 50 ± 2 °C, for not less than 7 days and not more than 8 days.
- b) Carry out the testing in a room maintained at 23 ± 2 °C.
- c) Remove the specimens from the oven and immediately place them in the desiccator (maintained at 23 ± 2 °C) for cooling. Allow the specimens to cool for a minimum of 2 hours and a maximum of 4 hours. Remove the specimens from the desiccator and start the testing in accordance with the procedure outlined in 4.6 a) to o) (inclusive) within 30 min.
- d) Measure and record, to an accuracy of 0.02 mm, the thickness and diameter of each specimen with the Vernier calliper at four points equally spaced around the

perimeter of the specimen. Calculate and record, to the nearest 0.02 mm, the average of each set of four readings.

4.6 TESTING OF SPECIMENS

- a) Determine the dry mass of the specimens (M_d) to an accuracy of 0.01 g and record.
- b) Place the specimens in the vacuum saturation tank.

Note: The specimens should be arranged so as to maximize their exposed surface area. This may be achieved by standing the individual specimens upon their curved edges, rather than the flat side, as in Figure 3.5, Part 3.

- c) Seal and close the vacuum saturation tank.
- d) Evacuate the tank to between -75 kPa and -80 kPa, and maintain this vacuum for 3 h \pm 15 min.
- e) Isolate the tank and allow salt solution to flow into the chamber until the water level is approximately 40 mm above the top of the specimens. Ensure that no air enters the chamber during this procedure.
- f) Re-establish the vacuum in the tank to between -75 and -80 kPa, and maintain this vacuum for 1 hour \pm 15 minutes.
- g) Release the vacuum and allow air to enter the chamber. Allow the specimens to soak in the salt solution for a further 18 \pm 1 hours.
- h) Remove the specimens from the solution, dry them to the saturated surface dry condition and immediately weigh to an accuracy of 0.01 g. Record this as the vacuum saturated mass (M_s) of the specimen.
- i) Unscrew the connection points of the conduction cells and fill the plastic tubes (Luggin capillaries, shown in Figure 4.2) of the chloride cell and both chambers of the cell with the 5.0 M NaCl solution.



Figure 4.2: Luggin



Figure 4.3: Connecting point of chloride conductivity cell

- j) With the flexible rubber collar in the central ring portion of the cells, place a concrete specimen within the collar, ensuring that it is placed with one face against the plastic lip of the rigid ring, as in Figure 4.4.

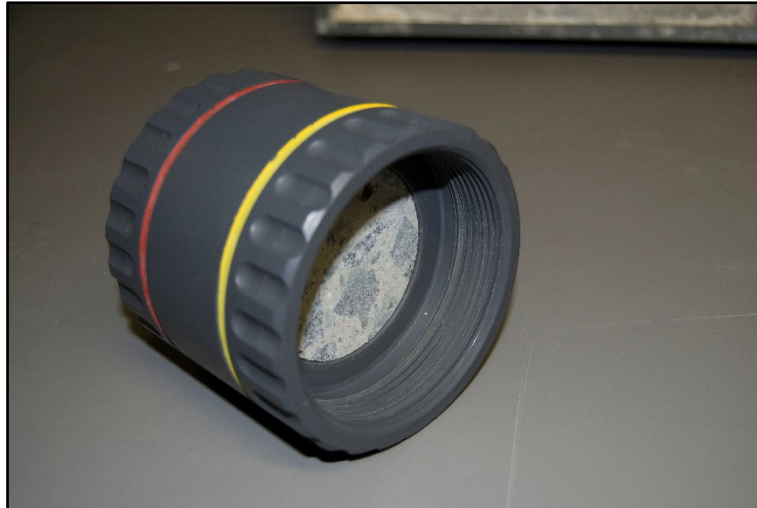

Figure 4.4: Properly placed specimen in collar

- k) Screw the anode and cathode sections of the cell into the central portion. Tighten both parts sealing the specimen, and ensure that there are no signs of leakage. See Figure 4.5.
- l) Place the assembled test rig (anode, cathode and central portion) to stand upright on a horizontal surface, and completely fill both the anode and cathode compartments in turn with the 5 M NaCl solution through the holes in each compartment (see Figure 4.1 a) and b). Seal the holes with the cap-screws and ensure that there are no signs of leakage.
- m) Connect the ammeter and the voltmeter, as shown in figure 4.1, and adjust the DC power supply until the voltage applied across the specimen (capillary voltage) is approximately 10 V.

Note: The voltage across the specimen is read from the voltmeter; it is not the voltage indicated in the DC power supply.

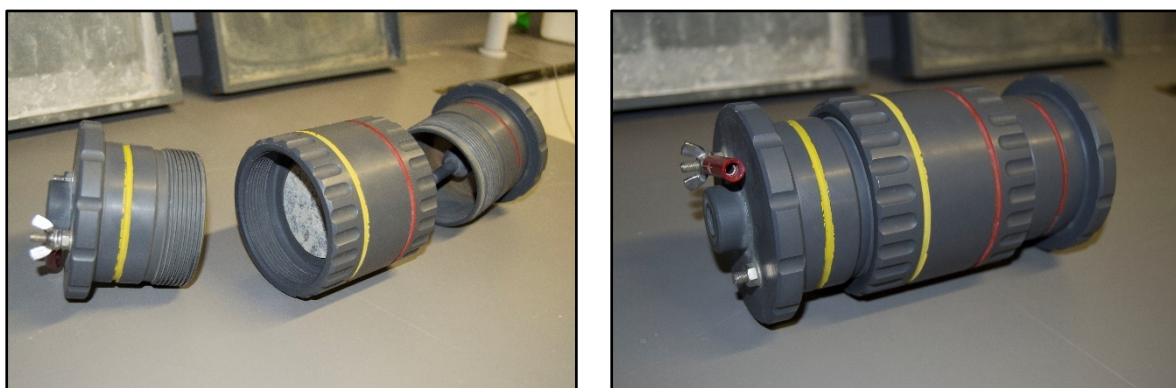

Figure 4.5: Alignment of cells for proper sealing

- n) Simultaneously record the current and voltage readings from the ammeter and voltmeter respectively. Upon switching on the power supply in the test circuit, the capillary voltage should be quickly adjusted to approximately 10 V and the current and corresponding capillary voltage across the specimen recorded within 10 seconds. Switch off the circuit (i.e. power supply) as soon as possible.

- o) Testing should be completed within 15 min of removing a specimen from the NaCl solution.

Note: Specimens can be re-tested within 30 minutes of the first test, but should be discarded thereafter. Specimens should be stored in the NaCl solution before retesting.

4.7 CALCULATIONS

- b) Determine the chloride conductivity of each specimen by applying the following formula:

$$\sigma = \frac{id}{VA} \quad (4.1)$$

where:

- σ is the chloride conductivity of the specimen (mS/cm)
 - i is the electric current (mA)
 - d is the average thickness of specimen (cm)
 - V is the voltage difference (V)
 - A is the cross-sectional area of the specimen (cm²)
- b) Determine the chloride conductivity index as the average of the chloride conductivity of the four test specimens. Where one specimen has been discarded, the chloride conductivity index may be calculated from the average of at least three valid test specimens.
- c) Determine the chloride solution porosity of the specimen by applying the following equation:

$$n = \frac{(M_s - M_d)}{Ad\rho_s} \times 100 \quad (4.2)$$

where:

- n is the porosity as a fraction of the volume of the specimen that is occupied with the solution, as a percentage (%).
- M_s is the vacuum saturated mass of the specimen determined in section 4.6 h) to the nearest 0.01 g, in grams (g).
- M_d is the mass of the dry specimen determined in section 4.6 a) to the nearest 0.01 g, in grams (g).
- A is the cross-sectional area of the specimen to the nearest 0.02 mm² in square millimetres (mm²).
- d is the average specimen thickness to the nearest 0.02 mm, in millimetres.
- ρ_s is the density of salt solution (i.e., 1.19×10^{-3} g/mm³), in grams per cubic millimetre (g/mm³).

Note 1: It has been found that the porosity determined from the chloride conductivity test is normally lower than that determined in the sorptivity test.

Note 2: The repeatability and reproducibility of chloride conductivity tests are given in Appendix A.

4.8 REPORTING

The test report shall include the following information:

- a) Identification mark of the specimen.
- b) A detailed description of the specimen.
- c) The chloride conductivity of each individual specimen.
- d) The chloride conductivity index to the nearest 2 decimal places.
- e) The porosity of each specimen expressed as a percentage to two decimal places.

The test report shall also include the following information, if known:

- f) The source of the specimen.
- g) The location of specimen within cube, core or member
- h) Identification mark of each specimen
- i) The type of concrete, including binder type, water/cement ratio and other relevant data supplied with the specimen.
- j) Curing history.
- k) Unusual specimen preparation, for example removal of surface treatment.
- l) Unusual features such as cracks, voids, and excessively chipped edges.
- m) The name of the test officer.
- n) The age of concrete at time of testing.

4.9 REFERENCES

- (1) Alexander MG, Ballim Y, Mackechnie JM, 'Concrete durability index testing manual' Research Monograph no. 4, Departments of Civil Engineering, University of Cape Town and University of the Witwatersrand, March 1999
- (2) Mackechnie JR and Alexander MG, 'Practical considerations for rapid chloride conductivity testing.' Proceedings of the Second International Workshop on Testing and Modelling the Chloride Ingress Into Concrete, C. Andrade and J. Kropp, ed., 2000.
- (3) Gouws SM, 'Durability index approach – method statements.' Document submitted to the Durability Index Test Method working group (Under the auspices of the C&CI Technical Committee), University of the Witwatersrand, 14 August 2003.
- (4) Gouws SM, 'Durability Index Approach – Progress Report 1: Method Statements' Summary document of major amendments to Durability Index Test Methods as agreed upon by Durability Index Test Method working group (Under the auspices of the C&CI Technical Committee, University of the Witwatersrand, 19 August 2003.

- (5) Gouws SM, 'Durability Index Approach – Progress Report 2: Method Statements' Summary document of major amendments to Durability Index Test Methods as agreed upon by Durability Index Test Method working group (Under the auspices of the C&CI Technical Committee, University of the Witwatersrand, 7 October 2003.
- (6) Otieno M, Alexander MG, 'Chloride conductivity testing of concrete – past and recent developments.' Journal of the South African Institution of Civil Engineering 57(4): 55-64, December 2015.
- (7) Mukadam Z, Alexander M.G., Beushausen H.D., 'The effects of drying preconditioning on the South African durability index tests.' Cement and Concrete Composites (69): 1-8, 2016.
- (8) Stanish, K., Alexander, M. G. and Ballim, Y., (2001), Assessing the repeatability and reproducibility values of South African durability index tests, SAICE Journal, Vol. 48(2), pp. 10-17.
- (9) ASTM C 802-14, 2014, "Standard Practice for Conducting an Inter-laboratory Test Program to Determine the Precision of Test Methods for Construction Materials," ASTM International.
- (10) ASTM C 670-90, 2015, "Standard Practice for Preparing Precision and Bias Statements for Test Methods for Construction Materials," ASTM International.
- (11) Otieno, M., 2018, "Sensitivity of the rapid chloride conductivity index test to concrete quality and changes in various test parameters. Cement and Concrete Composites 86 (2018) 110 -116.

4.10 REVISIONS

Note: Revisions below may refer to older versions with different clause numbers to this version.

Revisions	Description	Date
A	For approval	8 April 2002
B	Indicated with subscript B	15 May 2002
C	K. Stanish (KS) – remove marked with strike through, added in bold, comments in italics	19 Feb 2003
C1	S. Gouws (SG) – suggested changes in red, <i>questions and remarks in italics, see also reference 3</i>	16 July 2003
D	Skipped	
E	For approval after Durability Index Test Method meeting 22 September 2003, see also reference 5.	22 September 2003
F	Editorial improvements and clarifications – M. G. Alexander (MGA)	April-July 2004
G	KS – Clarification and illustration	April/May 2005
H	MGA – Editorial corrections	Jan/Oct 2007
I	MGA – Editorial and other corrections	Sep-Oct 2008
J	All MGA New Cl 4 b) inserted; other clause numbers in Cl. 4. changed accordingly	25 Feb 2009

Revisions	Description	Date
	Cl. 6 a): 't' changed to 'd' for specimen thickness; ditto Cl. 6 c)	
K	SG with MGA Cl. 1 j): Must cool in desiccators only Cl. 2 a): Changed 'tap' to 'potable' Cl. 6 c): change t to d in the calculation to be consistent	May 2010
L	MGA & Chad Ludwig (CL) – Editorial changes; also to correspond to SANS 3001-CO3-3:2015 (CCI)	Oct-Nov 2016
M	MGA / MO. Changed 1s% to Coefficient of Variation (CoV), App A	12 July 2017
N	MO – Added test duration	Dec 2017

APPENDIX A (Part 4)

Precision: Repeatability and reproducibility of chloride conductivity tests

Typical ranges of within test coefficient of variation and multi-laboratory precision are provided in Table A.1. These values may be refined from time to time as additional data become available. These data derive mainly from inter-laboratory test programmes aimed at establishing repeatability and reproducibility data. In general, in excess of 30 test results were available.

Table A.1 — Guideline summary of repeatability and reproducibility values

1	2
Repeatability and reproducibility	CCI
Repeatability (Coefficient of Variation (%))	CoV (%) ^a
Laboratory data	5,0 – 10,0
Ready mix concrete data	5,0 – 10,0
Site data	10,0 – 15,0
Reproducibility (Coefficient of Variation (%))	CoV (%) ^b
Laboratory data	21,1
^a Single operator coefficient of variation	
^b Between laboratory coefficient of variation	